



TECHNICAL GUIDE

PATENTED DESIGN



We recommend
250-320 g
Polyester banner
material or similar

GB Free-standing wall with 3 sections for banners of 2 different heights. Can be used both single- and double sided. Delivered in convenient transport box with all parts incl. hangers and aluminium profiles for mounting of singlesided banner. Banner not included.

DE Einzel stehende Wand mit 3 Sektionen für Banner in 2 verschiedene Grössen. Kann sowohl einseitig als auch doppelseitig bestückt werden. Wird in einem praktischen Transportkasten geliefert. Einschliesslich alle Module, Aufhängeklipps und Bannerleisten für einseitige Bestückung. Exklusiv Banner.

DK Fritstående væg med 3 sektioner til bannere i 2 forskellige højder. Kan benyttes enkelt- såvel som dobbeltsidet. Leveres i praktisk transportkasse med alle dele samt ophængsbeslag og bannerlister til enkelt-sided banner. Leveres uden banner.

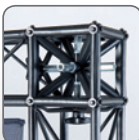

LOWER PART:

- 7 x
- 4 x
- 4 x

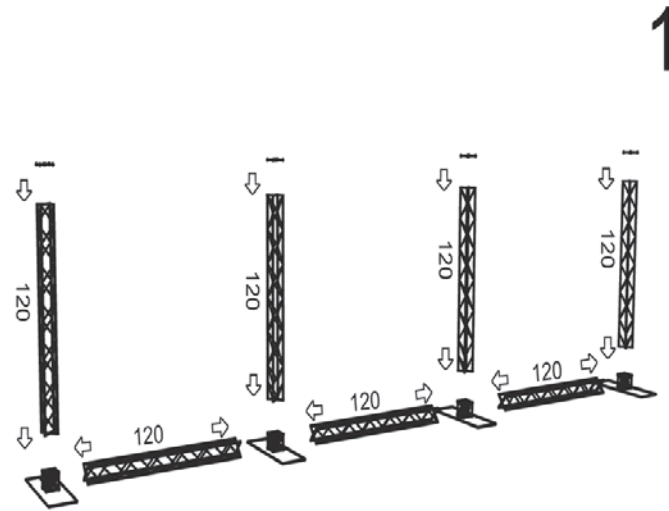

UPPER PART:

- 9 x
- 6 x

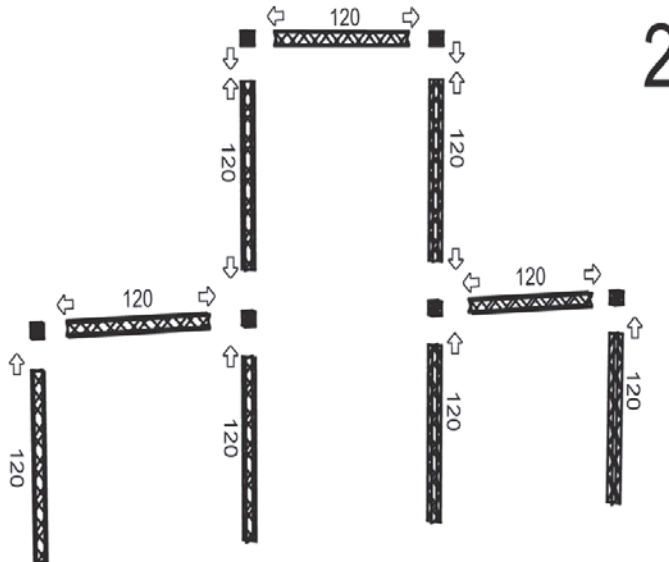

ASSEMBLY:

Install Banner.

Mount upper part at top of lower part.

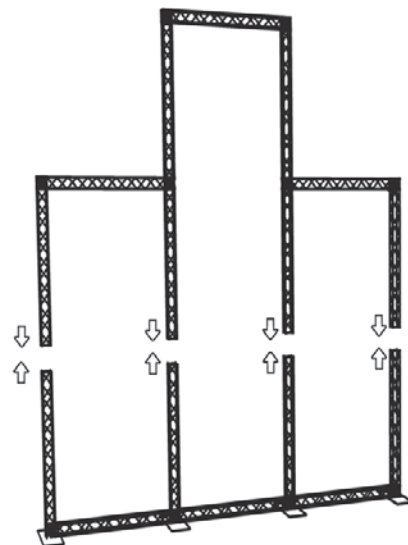

Art.no.	Model	Banner size	Colour	Total W x H	Package Size	- weight	Pallet size	- quantity
2256	756	2 pcs. 119 x 238 + 1 pc. 119 x 368 cm	Black	400 x 390 cm	43 x 123 x 42 cm	33,5 kg	86 x 125 x 220 cm	10 pcs.